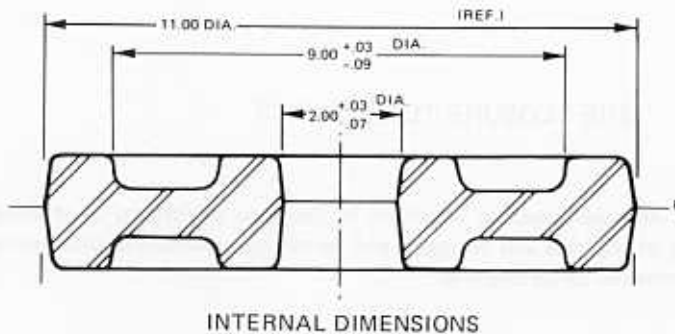

Fig. 4



HAMMER, PRESS



METRIC CONVERSION	
INCH	mm
.03	.8
.07	1.8
.09	2.3
2.00	50.8
9.00	228.6

COMPUTATION INTERNAL DIMENSIONS
MATERIAL: CARBON STEEL

EXAMPLE 7
(SEE FIGURE 4)

	Tolerance on Internal Dimension	Plus	Minus
INCH	Diameter x Length/Width Tolerance factor = 9 x 0.003 =	0.027	0.027
	Largest Diameter x Die Wear Tolerance factor = 11 x 0.005 =	---	0.055
	(Table I, page 9)	+0.027	-0.082
	Raised to the next highest .01 in.	+0.03	-0.09
METRIC	Diameter x Length/Width Tolerance factor = 228.6 x 0.003 =	0.686	0.686
	Largest Diameter x Die Wear Tolerance factor = 279.4 x 0.005 =	---	1.397
	(Table I, page 9)	+0.686	-2.083
	Raised to the next highest .1 mm	+0.7	-2.1
	Minimum Tolerance (paragraph 2, page 8)	+0.8	

EXAMPLE 8
(SEE FIGURE 4)

	Tolerance on Internal Dimension	Plus	Minus
INCH	Diameter x Length/Width Tolerance factor = 2 x 0.003 =	0.006	0.006
	Largest Diameter x Die Wear Tolerance factor = 11 x 0.005 =	---	0.055
	(Table I, page 9)	+0.006	-0.061
	Raised to the next highest .01 in.	+0.01	-0.07
	Minimum Tolerance (paragraph 2, page 8)	+0.03	
METRIC	Diameter x Length/Width Tolerance factor = 50.8 x 0.003 =	0.152	0.152
	Largest Diameter x Die Wear Tolerance factor = 279.4 x 0.005 =	---	1.397
	(Table I, page 9)	+0.152	-1.549
	Raised to the next highest .1 mm	+0.2	-1.6
	Minimum Tolerance (paragraph 2, page 8)	+0.8	